

Web Tension Transmitter



FEATURES

- Ultra high speed 120 update-per-second, isolated 4-20mA current output
- Compact, full function web tension indication/control
- DIN Rail mount capability
- 700,000 count resolution; eight millisecond sample rate
- Two (2) load cells per tension zone
- 8 open collector discrete setpoint outputs

DESCRIPTION

PS-2010T Transmitters offer precision web tension measurement for applications that require a small, full function indicator/controller. Packaged much like a mini-PLC 'brick', units can be DIN rail mounted inside any existing cabinet. The standard RS-485 serial port interfaces easily with PLC/DCS systems using conventional ASCII or optional Modbus RTU protocol. A high speed, high resolution, isolated (16 bit) 4-20mA analog output provides the perfect input for a brake/clutch motor controller.

Simple set-up and calibration is performed using the integral LCD display and keypad assembly. Digital calibration techniques eliminate the need for costly, cumbersome machine "strapping" in most applications and greatly simplify the calibration of systems that do require loading. Standard

units also include Dynamic Digital Filtering and eight setpoints.

Both the front panel display and the 16 bit analog output are updated every 8.3 milliseconds (120 updates per second). This rate provides precise control for web applications running at 2000 feet per minute and faster.

Quick calibration and setup procedures save time, money, and even field service calls. On-line diagnostics continuously monitor system performance and alert service personnel to potential problems before they happen.

The 2010 offers a cost effective, reliable solution for the OEM and system integrator.

APPLICATIONS

- Paper machines
- Film/foil/filament converting
- Textile web measurement
- Roofing machines

CONFIGURATION

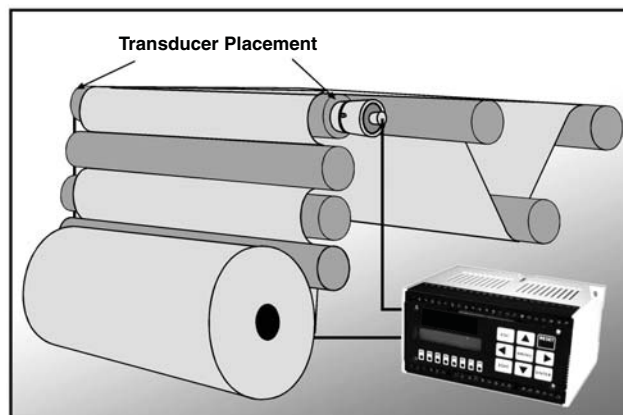

SPECIFICATIONS

Performance

Resolution	1,048,576 total counts
Displayed Resolution	700,000 counts
Conversion Speed	8.3 to 133msec (5-selections) (7.5 to 120 updates/second)
Displayed Sensitivity	0.05µV per count
Noise	0.4µV per count (min. filt setting)
Full Scale Range	±3.5mV/V
Bipolar Direction	±100% full scale
Input Impedance	10m-ohms min
Excitation Voltage	10Vdc @ 240mA
Linearity	±0.003% full scale
Step Response	one conversion

Transducer Supply

Excitation	10 Volts DC
Gage Resistance	350 Ohms
Gage Type	foil (2-3mV/V), full bridge
Number of Load Cells	two (2) cells per tension zone

Environment

Operating Temperature	-10 to 50°C (15 to 122°F)
Storage Temperature	-25 to 80°C (-10 to 175°F)
Temp Coefficient Zero	±2ppm/°C
Temp Coefficient Span	±7ppm/°C
Operating Humidity	95% rh non-condensing

Electrical

Voltage (AC)	117/230Vac ±15% @ 50/60Hz
Voltage (DC)	24Vdc @ 1A
Power	12 watts typical, 18 watts max

Display

Type	single line LCD
Active Digits	16 digit alpha numeric 0.24" high
Display Units	PLI, LB, KG, N, N/M

Analog Output; 16 Bit D-A

Current	4-20mA - 500 ohm max.
---------	-----------------------

Communications

Serial RS485/422	full or half duplex ASCII protocol 7 or 8 data bits- selectable odd, even or no parity- selectable Baud Rates 300, 600, 1200, 2400, 4800, 9600, or 19200
------------------	--

Special Interface (Optional)

Modbus RTU	Slave
------------	-------

Remote Inputs - 4

Type	TTL or dry contact closure
Functions	total tension, zero and print
Low	0.0 to 0.4Vdc
High	4.0 to 24Vdc

Set Point Outputs - 8

Type	open collector (current sinking)
Operating Voltage	5 - 35Vdc
ON Voltage	1.2Vdc @ 35mA 0.8Vdc @ 1mA
OFF State Leakage Power	0.04A @ 35Vdc external supply required

Approvals

CSA	Class I, Div. 2; Groups A, B, C, (when mounted in a CSA certified enclosure)
-----	--

Enclosure Mounting Dimensions

Standard Unit	5.8 x 3.0 x 4.3in. LxWxD DIN rail or wall mount weight approx 3 pounds
Single Unit NEMA 4X Enclosure	11.73 x 9.85 x 6.13in. LxWxD with single DIN rail mounting strip
Double Unit NEMA 4X Enclosure	13.7 x 11.8 x 6.5in. LxWxD with two DIN rail mounting strips

Materials

Enclosure (standard)	polycarbonate
----------------------	---------------

OUTLINE DIMENSIONS

